



Model 2140

AES/EBU audio shuffler

February 2002

BEL (Digital Audio) Ltd.
3 Horwood Court, Bletchley, Milton Keynes, MK1 1RD UK
Tel: +44 (0) 1908 641063 Fax: +44 (0) 1908 641063
Email: sales@beldigital.com Web: www.beldigital.com

Contents

INTRODUCTION	4
FEATURES	4
Input Switching	4
Phase Reversal	4
Analog Outputs	4
Monitor Outputs	4
Digital I/O	5
Insert Bus	5
Memory	5
Keyboard Lock	5
FRONT PANEL KEYS	6
LCD Display	6
Nudge \wedge \vee	6
Set	6
Input/Output	6
FAD	5
MAT	6
BYP	7
LOCK	7
Monitor Gain and Output Jack	7
OPERATION	8
Matrix Mode Operation	8
Mixer Mode Operation	8
Setup	9
Memory Functions	9
Mode	9
Monitor Source	9
Input Source	9
Reference Source	9
Communications Address	10
RS422 Serial Control	10
Rear Panel Connectors	10

PIN CONNECTIONS	11
Audio Outputs	11
Insert Bus I/O	11
RS422 In	11
RS422 Out	11
EMC COMPLIANCE	12
SPECIFICATION	13
SERIAL PROTOCOLS (RS422)	14
Overview	14
Frame Format	14
Start Flag	14
Destination Address	14
Source Address	14
Command	14
Data Count	15
Data	15
Checksum	15
End Flag	15
COMMANDS (RS422)	16
REPLIES (RS422)	16
INPUT GAINS FORMAT (RS422)	16
GENERAL DATA FORMAT (RS422)	17
FRONT VIEW OF UNIT	18
DETAIL OF SWITCHES ON FRONT	19
DEFAULT LCD	19
REAR PANEL VIEW	19
2140 BLOCK DIAGRAM (SHEET 1)	20
2140 BLOCK DIAGRAM (SHEET 2)	21
TROUBLE SHOOTING	22

BEL 2140

AES/EBU Audio Shuffler

INTRODUCTION

The main function of the Bel 2140 is to offer a cost effective solution to modifying AES/EBU audio signals in the digital domain. The main areas of use are where occasional or minor corrections to standard practice are required such as in transmission, racks and VT areas. The Shuffler is designed to allow 4 AES/EBU audio input signals to be selected, modified and then routed to 4 digital outputs. Four high quality analogue outputs are provided which reflect the digital outputs. A headphone monitor jack is also provided on the front panel. The unit can be controlled by front panel switches or remotely.

FEATURES

INPUT SWITCHING

The unit can operate in one of two modes, Matrix or Mixer. In the Matrix mode any single input can be selected and directed to any output. In the Mixer mode any combination of inputs can be selected, mixed and directed to any output.

INPUT GAINS

In either mode gain can be applied to the selected inputs before redirection or mixing. The gain can be adjusted over the range +10 to -30 dB (in 1dB steps).

PHASE REVERSAL

In either mode the selected inputs can be phase reversed before redirection or mixing.

ANALOG OUTPUTS

The BEL 2140 provides 4 high quality analogue outputs which carry the same audio data as the corresponding digital outputs. The outputs are provided on a 9 way D type connector on the back panel. Fig 4.

MONITOR OUTPUTS

A stereo headphone output is provided on the front panel to allow any pair of outputs to be monitored. The signals on the left and right monitor outputs can be selected via the setup system.

DIGITAL I/O

The BEL 2140 provides a fully synchronised AES EBU compatible digital audio interface. A sample rate converter is used on the inputs allowing the conversion of 32kHz, 44.1kHz digital sources to 48kHz outputs. A digital referencing system is employed which will synchronise the digital output to various types of reference input. (Internal, AES and optionally word/video). The digital AES reference input can be used with sampling rates other than 48kHz but the unit is optimised for 48kHz.

If the power supply to the unit fails an electro-mechanical system will connect the digital inputs directly to the digital outputs so providing a degree of fault tolerance.

INSERT BUS

A 4 channel digital Input/Output bus is provided. This facility allows the 2140 to pass audio data to an external processor. Audio data provided on this bus by other equipment can be used to replace that on the normal input channels. It is intended for use when the input audio requires an equalizer or a delay etc. before mixing and outputting. There is no sample rate conversion applied to the bus input; it is intended for 48kHz sources.

MEMORY

The operating mode and current setup are stored in one of eight memories and this information is retained when the unit is switched off. The memory can be reset to the factory default settings by depressing any key while the BEL logo is displayed and 'set' key to confirm at power on.

KEYBOARD LOCK

Inadvertent operation of the keys can be avoided by invoking the key 'lock' function. The unit will power-on with the keys in a locked state if the internal DIL switch SW 4 position 1 is on, refer to the lock section before attempting adjustments.

FRONT PANEL KEYS

Several push buttons and indicators are located on the front panel, Fig 1 and Fig 2, from left to right these are:-

LCD DISPLAY

On power-up the LCD will show model number, software version and model description for a few seconds before resetting to the default display. Fig 3. In its default mode the LCD will display:

- Current input to output connections.
- Gains and phase reversal settings for each input.
- Memory number
- State of the FAD, MAT, BYP and LOCK switches.

NUDGE UP/DOWN ^ v

These buttons are used to adjust input gains and the value of parameters within the setup menus.

SET

This key will enter the setup menus. See setup section for details of the setup operation.

INPUT/OUTPUT

Two horizontal rows of switches control the input and output, selection. The upper row marked 1 to 4 are the input selection switches. The lower row are the output selectors. A red LED indicator positioned beneath each input switch will show the currently active input channel. See below for detail of their use.

FAD

This switch is only functional in the matrix mode and can be used to override any gain adjustments imposed on the input audio. If the word Fad is not displayed on the upper line of the LCD display all inputs are passed to the selected outputs without gain adjustment.

MAT

This switch is only functional in the matrix mode and can be used to override any redirection imposed on the input audio. If the word Mat is not displayed on the upper line of the LCD display all inputs are passed to their appropriate output. i.e. in1 to out1, in2 to out2 etc.

BYP

This switch will activate an electronic bypass which is a combination of FAD, INV and MAT. No gain adjustment inversion or redirection of the inputs occurs when the word Byp is shown on the upper line of the LCD display.

LOCK

When the unit is `locked' all the front panel keys, except LOCK, are inoperative. To release the keys press and hold the LOCK key for a period in excess of five seconds. A momentary press of the LOCK key will again place the unit in the lock mode. The locked mode is indicated by the word Lock on the upper line of the LCD display.

MONITOR GAIN AND OUTPUT JACK

The headphone monitor output is available from this gain control and 6 mm stereo Jack.

OPERATION

The BEL 2140 Shuffler can operate in either the Matrix or the Mixer mode:

MATRIX MODE OPERATION

In this mode of operation each of the four output channels can have one of the inputs associated with it. The inputs can be derived from the main AES inputs or a pair from the insert bus. The gain and phase of each input can be modified, depending on the state of the FAD, MAT and BYP controls, before being passed to the output. The LCD display, in this mode, shows the 4 output channels, their associated input and its gain or phase modification.

To operate in the Matrix mode first ensure that Matrix is selected in the setup menu. The Matrix mode may be identified if the amber LED to the right of input switch 4 is extinguished. Then select the OUTPUT required by depressing the appropriate numbered switch on the lower horizontal row. The output selected will be indicated in reverse video on the LCD display, the current input channel associated with this output is indicated by the LED. If required the input channel can now be changed by depressing the required switch on the upper row. The gain of that channel can be adjusted by depressing the nudge \wedge \vee , the current gain will be shown on the LCD display. A phase reversal can be applied to the input channel by depressing the INV switch. The phase reversal is indicated by a \downarrow symbol in reverse video on the LCD display positioned beside the corresponding input.

MIXER MODE OPERATION

The mixer mode, identified by the amber LED, provides the facility to select and mix a combination of any inputs and direct the result to any output. As with the Matrix mode, gain and phase reversal can be applied to the selected inputs. In this mode the LCD display will show a different screen for each output selected. The display will indicate the gain and phase reversal of each input together with the current input for adjustment.

To operate in the Mixer mode first ensure that Mixer is selected in the setup menu. The amber LED to the right of input switch 4 is active. Then select the OUTPUT required by depressing the appropriate numbered switch on the lower horizontal row. The page corresponding to the output selected will be shown on the LCD display, the current input channel indicated by the corresponding LED and in reverse video on the LCD. If required the input channel for adjustment can now be changed by depressing the required switch on the upper row. The gain of that channel can be adjusted by depressing the nudge \wedge , the current gain will be shown on the LCD display. A phase reversal can be applied to the input channel by depressing the INV switch. The phase reversal is indicated by a \downarrow symbol in reverse video on the LCD display positioned beside the corresponding input.

Note that the FAD, MAT and BYP buttons are inoperative in this mode.

SETUP

The setup function of the 2140 is accessed by depressing the SET key. Parameters adjustable under setup can be made to appear sequentially by depressing the SET key. Each of the setup menus, with the exception of the memory recall, show values which can be adjusted by means of the nudge \wedge \vee keys. The setup menu will time-out after 10 seconds if no adjustment is made. The functions available in the setup are as follows:

MEMORY FUNCTIONS

The first press of the SET key will enter the memory recall state. The Mem indication on the LCD will appear in reverse video. It is possible to browse the states of the 8 memories by pressing the input and output selection keys. Input keys 1 to 4 will display the memory settings 1 to 4, output keys 1 to 4 will display the memory settings 5 to 8. The memory settings are merely displayed up to this point, to activate a particular memory first select the required number as described above and then press the same key a second time.

MODE

The operational mode of the unit, Matrix or Mixer, may be selected here. Selection is made employing the Nudge buttons.

MONITOR SOURCE

The output directed to the left or right monitor channel can be selected here. To select a channel for the right monitor source press the SET key and then make a selection, to return to the left monitor source select, press the input 1 key.

INPUT SOURCE

This setup item will only appear if the optional insert bus card is installed and DIL switch 3 is on. The input channel for inputs 1/2 and 3/4 can be selected here. The possible sources are internal, external 1/2 (insert bus) or external 3/4 (insert bus). To select the input 3/4 source press the SET key and then select the required input source, to return to the input 1/2 source select, press the input 1 key.

REFERENCE SOURCE

The source of the digital reference signal may be selected here. The possible sources are Internal, AES and Video or Word clock.

COMMUNICATIONS ADDRESS

This allows the address of the unit to be selected. The unit will only respond to serial commands that contain its address. The permitted range of addresses is 1 to 100.

RS422 SERIAL CONTROL

The BEL 2140 can be externally/ remotely controlled via the 9 pin RS422 socket on the rear panel. Units can be connected in cascade by linking the RS422 output connector of one unit to the RS422 input connector of the next. The RS422 signal is buffered by each unit and electro-mechanically bypassed during power down.

REAR PANEL CONNECTORS

From the left these are:

Analogue Outputs	15 way D female.
AES/EBU Digital inputs	2 XLR 3 Pin female connectors.
AES/EBU Digital outputs	2 XLR 3 Pin male connectors.
AES/EBU Digital reference	XLR 3 Pin female.
Video Reference	BNC optional 75 Ω termination.
Word clock reference	BNC 5k Ω termination.
Insert Bus	15 way D female
RS422 in serial Port	9 Pin D female.
RS422 out serial Port	9 Pin D female.
Voltage selection	230/115 VAC (voltage selectable).
Mains power and EMI filter	IEC 3 Pin, mains switch and fuseholder (230V - 250mA, 115V -500mA).

EMC COMPLIANCE

The BEL 2140 was designed and tested to comply with the EMC directive numbers EN55103, EN55022, EN55082-1 and EN60950 when used as directed.



Please ensure that wherever possible a 1U space is provided above and below the Bel 2140 to ensure that the unit is properly ventilated.

SPECIFICATION

Audio Inputs	2 pairs Stereo AES/EBU Digital
Digital audio sampling frequency	32-50kHz, nominally 48kHz
Digital Audio Outputs	2 pairs Stereo AES/EBU Digital
Analogue audio outputs	4 differential outputs.
D/A	24 bit. (better than 100 dB dynamic range)
level	+6dB out for -9 dB digital in. (Max. +15 dB, internally adjustable)
Output Impedance	50 Ω
Monitor output	2 channel analogue selectable audio sources 8 Ω min load impedance
Auxiliary I/O	External equipment bus
Word Length	Maximum 24 bit
Reference input	48kHz AES, Video/Word clock
Remote Interface	RS422, 9.6kBaud
Power Requirements	230/115 VAC, 35W
Dimensions	482w x 44h x 200
Net Weight	7kg

SERIAL PROTOCOLS

The subset of the BEL serial protocols for the 2140 is as follows:

OVERVIEW

Commands to be communicated to the remote unit (2140) are arranged in frames. These frame will then be sent to the remote unit which will always reply with either ACK for acceptance or NAK for rejection. Any requested reply then follows in the same frame format.

FRAME FORMAT

The frame starts with a start character 0xAA which is alternating ones and zeros. This is followed by the destination address, the source address, the command code, the data count, the data, a checksum and an end flag 0xFE.

Start Flag	0xAA
Destination Address	
Source Address	
Command	
Data Count	
Data	
Checksum	
End Flag	0xFE

START FLAG

The start flag 0xAA may be sent at any time. If sent during a frame this will cause the frame to effectively restart.

DESTINATION ADDRESS

This should be set to 1 for a 2140. This will be returned by the remote unit as the source address.

SOURCE ADDRESS

This should be set to 1 for 2140. This will be returned by the remote unit as the destination address.

COMMAND

This character is the command for the remote unit and must fall in the range 0x80 to 0xEF. More details of the relevant codes are shown below.

DATA COUNT

This is the total number of data bytes following, up to a maximum of 127.

DATA

The data required for the command is carried here. Each character can have a value of 0X00 to 0X7F i.e. 7 bits.

CHECKSUM

This is the modulo sum of characters in the frame between the destination address and the last data character inclusively. It is calculated thus:

```
DO
{
checksum = (character+checksum) AND 0x7F
}
FOR ALL CHARACTERS IN FRAME.
```

END FLAG

A character 0XFE ends the frame.

COMMANDS

Commands to the remote unit

Code(Hex)	Function	Reply
80	General prompt for a reply	C0 - ACK (OK) C1 - NAK (send again)
81	Use first data char as a second command	ACK
82	Request unit identifier	ACK then C2
85	Send memory number, Data count = 1 then memory number 0-7 (mem 1-8)	ACK
87	Request memory number	ACK then C7
8C	Parameter reset	ACK
8D	Send 16 input gains	ACK
8E	Request 16 input gains	ACK then CE
8F	Send general data	ACK
90	Request general data	ACK then D0

REPLIES

Replies, when requested (eg 82), will consist of frames which contain the original command value plus 0X40. So a request for an indent, 0x82, will elicit a reply of ACK then a frame containing 0xC2 and the indent string.

INPUT GAINS FORMAT

The input gains are represented in dB over the range -40 to +10 dB. To send these values two operations are required, firstly 40 is added to the gain resulting in a range of 0 to 50 and secondly if a phase reversal is present 0X40 is added to the result. This format will be recognised by the 2140 and the gain and phase reversal information placed in the current memory and mode.

GENERAL DATA FORMAT

The send and request general data (8F, 90) commands communicate most switch settings to PC and 2140. The format for these is:-

	Bit 7	Bit 6	Bit 5	Bit 4	Bit 3	Bit 2	Bit 1	Bit 0
Byte 0			Msb of bit 4	Input for out 3 Matrix mode	Msb of Bit 3	Input for out 2 Matrix mode	Msb of Bit 0	Input for out 1 Matrix mode
Byte 1		Msb of bit 5	Current output	Msb of bit 3	Current input	mode 1=Mix	Msb of Bit 0	Input for out 3 Matrix mode
Byte 2			Msb of Bit 4	Left monitor source	LOCK	BYP	MAT	FAD
Byte 3			Msb of Bit 4	3/4 input source	Msb of Bit 2	1/2 input source	Msb of Bit 0	Right monitor source
Byte 4							Msb of Bit 0	Reference source

The pair of bits labelled Input for output in Matrix mode is only relevant in the matrix mode and sets the current input associated with each output. The pair of bits labelled current input refer to the input which is currently selected. (Nudge or invert will modify this input).

RS422 format : 8 data bits, no parity, two stop bits, 9600 Baud.

FRONT VIEW OF UNIT

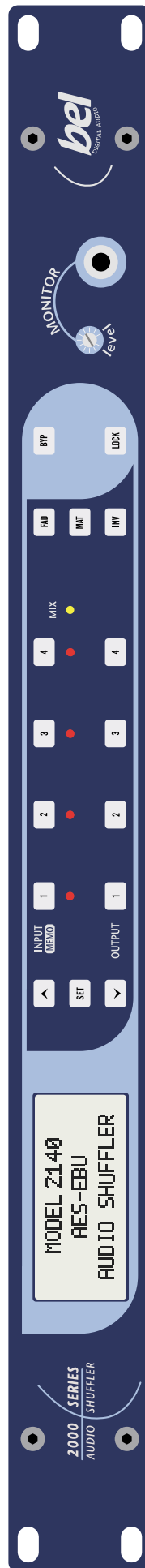

Figure 1

DETAIL OF SWITCHES ON FRONT

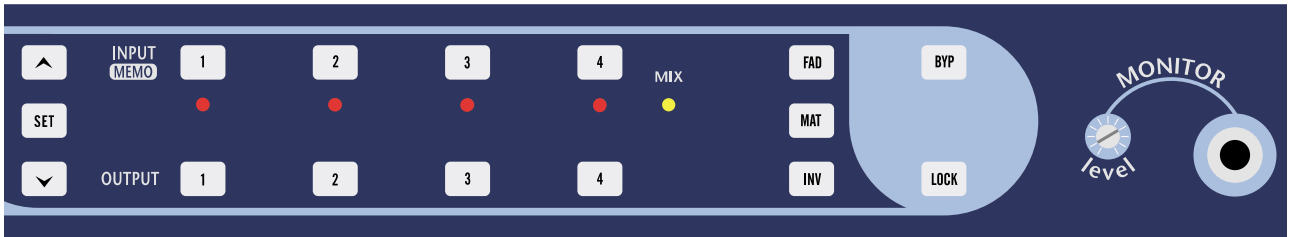

Figure 2

DEFAULT DISPLAY “MATRIX MODE”

Fad Mat			Lock Mem 1		
In 1	Out 1	0dB	In 2	Out 2	0dB
In 3	Out 3	0dB	In 4	Out 4	0dB

Figure 3

REAR PANEL VIEW



Figure 4

2140 BLOCK DIAGRAM

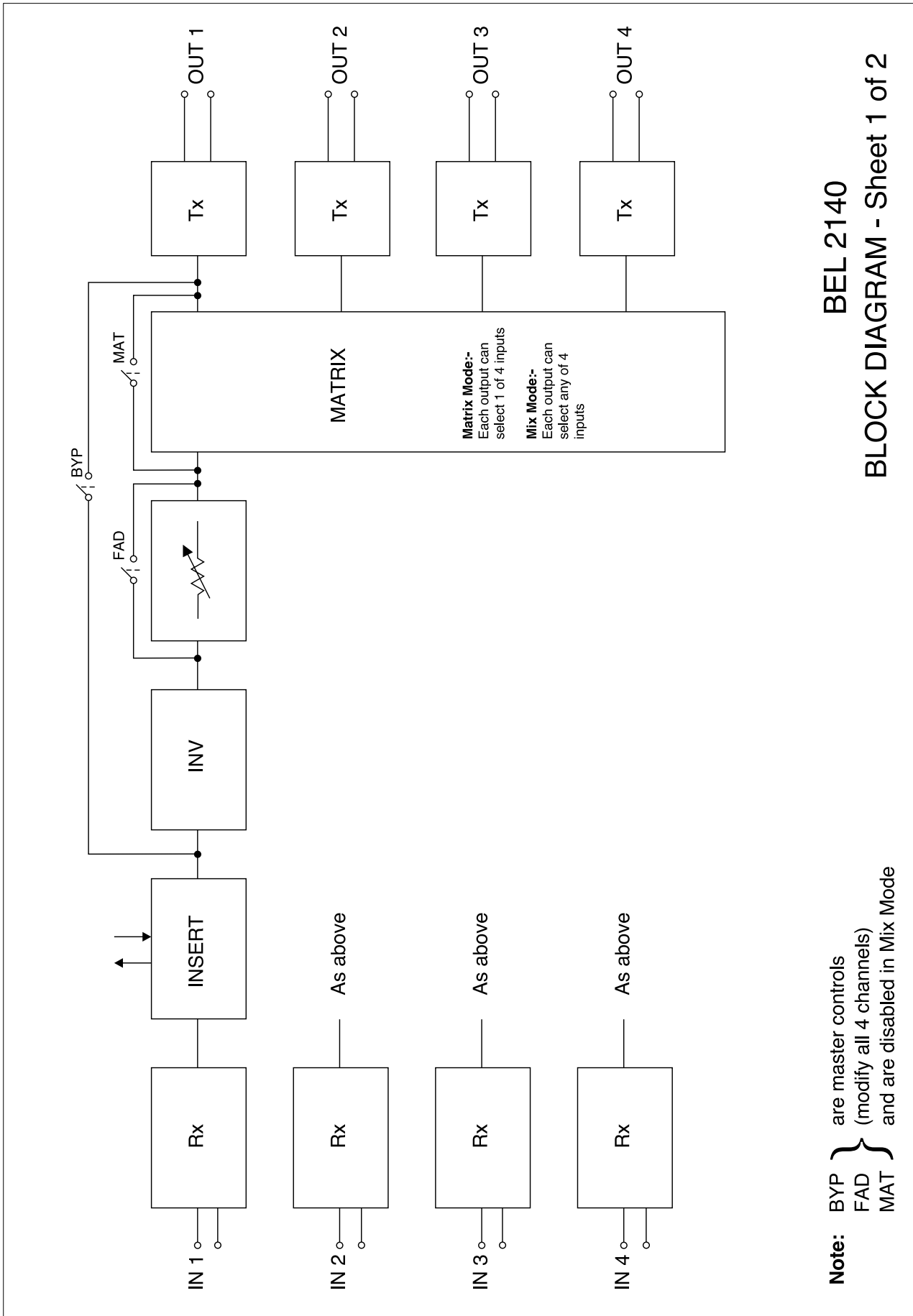

BEL 2140

BLOCK DIAGRAM - Sheet 1 of 2

2140 BLOCK DIAGRAM

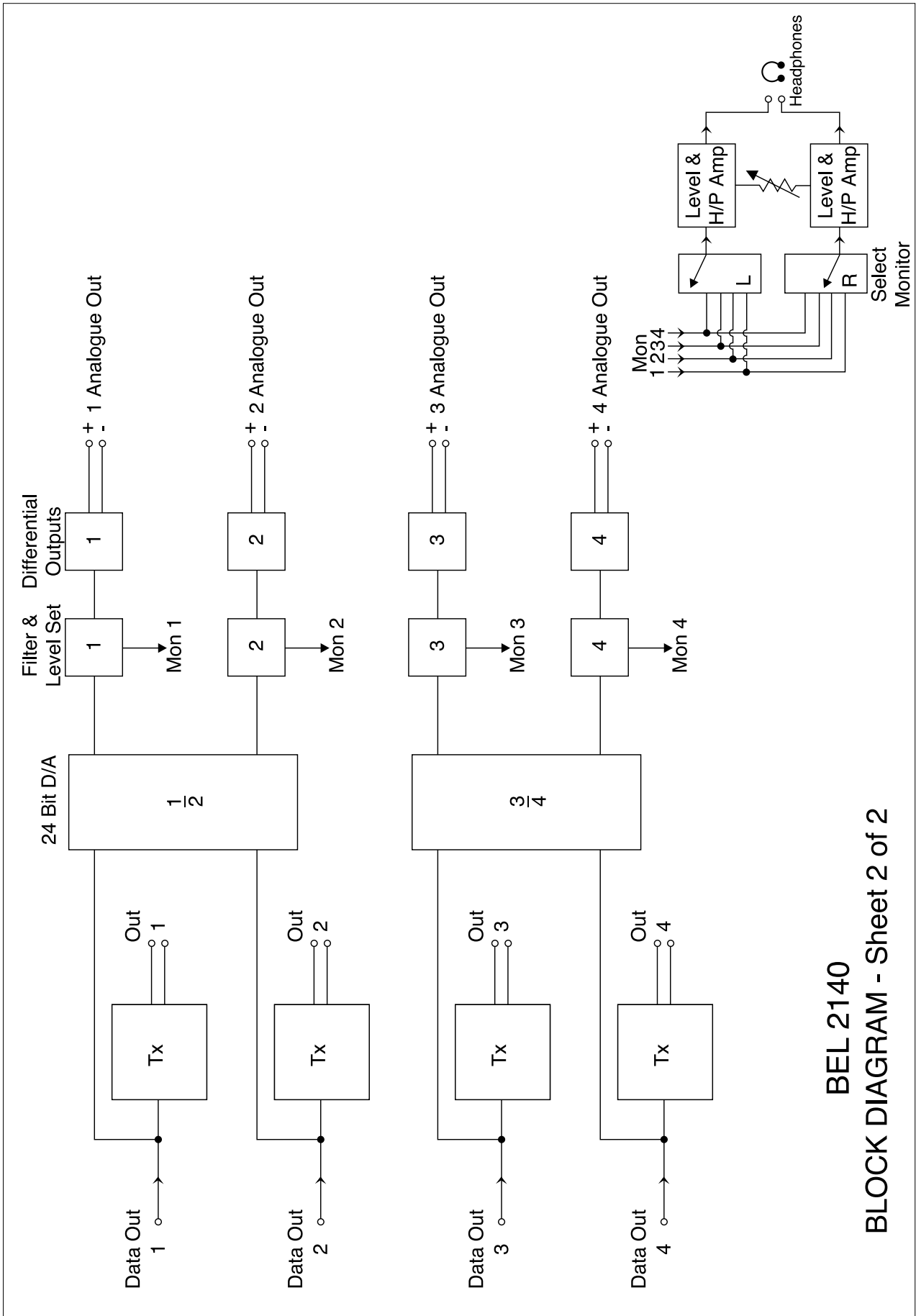

**BEL 2140
BLOCK DIAGRAM - Sheet 2 of 2**

TROUBLE SHOOTING

The BEL 2140 is designed and constructed to ensure a long and fault free life, but if a problem does occur the following guidelines are provided.

FAULT	CAUSES	ACTION
'Dead' unit	Power supply fault	Check fuses in the IEC and supply connector, then check fuses and connectors on the power supply PCB.
Only LCD backlight	Power supply fault	Check fuses on the power supply PCB
Power on message, then unresponsive	C-MOS RAM corruption	Reset memory to factory preset values by pressing any key while the power on message is visible 'set' key to confirm
No D/A audio outputs or monitor	No AES Digital inputs or no AES REF	Check AES inputs program and reference are connected. On the monitor selection check level control is set.
No monitor output	Monitor level control, Monitor input selection	Check level setting of control on monitor. Check monitor input select is set on channels with AES inputs to be monitored.

If the outline fault finding suggestions above are unsuccessful, contact your BEL distributor, or the main BEL distributor, who will advise you and arrange for the unit to be repaired.